

# 2636, 2641, 2644

## 6x4 Prime-mover Specifications

# Actros

125! years of innovation



**Mercedes-Benz**  
Trucks you can trust

<b>Engine</b>		<b>Chassis</b>	
Type	Mercedes-Benz OM 501 LA 11.9 litre turbocharged V6 360 - 435 hp (1,365 - 1,550 lb.ft) (See Actros Engines brochure for complete engine specification details)	Main rail	286 mm web x 70 mm flange x 8.0 mm thickness High strength E 500 TM steel ECE-R93, Front Underrun Protection Device (FUPD)
<b>Transmission</b>		Exhaust system	SCR catalytic converter with downswept outlet on LHS
Type	Mercedes PowerShift 2 G330-12/11.63-0.77 12 speed constant-mesh automated mechanical transmission	<b>Brakes</b>	
<b>Clutch</b>		Front/rear	Disc brakes 430 mm diameter Telligent <sup>®</sup> electro-pneumatic braking (EBS)
Type	Self-adjusting single dry plate	Service	10 bar operating pressure Automatic adjustment Air dryer ABS (anti-lock brakes) & ASR traction control Roll back prevention Telligent <sup>®</sup> Stability Control (ESP)* Active Brake Assist 2* autonomous emergency braking
Diameter	430 mm	Trailer	2 line trailer brakes with hand control Air and electrical lines behind cab
<b>Axles</b>		Engine brake	Active Engine Brake (AEB)
Front	Mercedes-Benz 7,500 kg capacity	<b>Cab</b>	
Drive	Mercedes-Benz 2 x 13,000 kg capacity Planetary hub reduction 233 mm crown wheel Inter-axle and cross-axle differential locks	Type	M (medium) cab ECE-R29 compliant cab Driver's airbag and seatbelt pre-tensioner (See Actros Cabins brochure for complete cab specification details)
Ratio	3.714 - 1,505 rpm @ 100 km/h	<b>Steering</b>	
<b>Suspension</b>		Type	Mercedes-Benz recirculating ball Integral power assistance Soft-feel 450 mm steering wheel Fully adjustable for height and rake
<b>Steel / Steel</b>		<b>Wheels and tyres</b>	
Front axle	Mercedes-Benz 3 leaf parabolic springs Stabiliser bar and shock absorber 8,000 kg capacity	Wheels	10-stud 8.25 x 22.5 steel wheels
Rear axle	Mercedes-Benz 6 rod with parabolic springs Stabiliser bar and shock absorbers 2 x 9,500 kg capacity	Tyres	Steer - 295/80 R 22.5 Drive - 11 R 22.5
<b>Steel / Air</b>		<b>Electrical system</b>	
Front axle	Mercedes-Benz 2 leaf parabolic springs Stabiliser bar and shock absorber 7,100 kg capacity	Voltage	24 volts
Rear axle	Mercedes-Benz 8 bag air suspension Stabiliser bar and shock absorbers 2 x 10,000 kg capacity Telligent <sup>®</sup> level control	Batteries	2 x 12 V/165 Ah
<b>Tank capacity</b>		Alternator	28 V/80 A
Diesel tank	1 x 400 litre rectangular aluminium tank on RHS	Starter	6.2 kW/24 V
AdBlue tank	1 x 85 litre rectangular plastic tank on RHS	Road lights	Halogen headlights
		Fuses	Automatic fuses
		Body Builder	Interface Module (PSM)

# Actros, 2636, 2641, 2644

## 6x4 Prime-mover Specifications

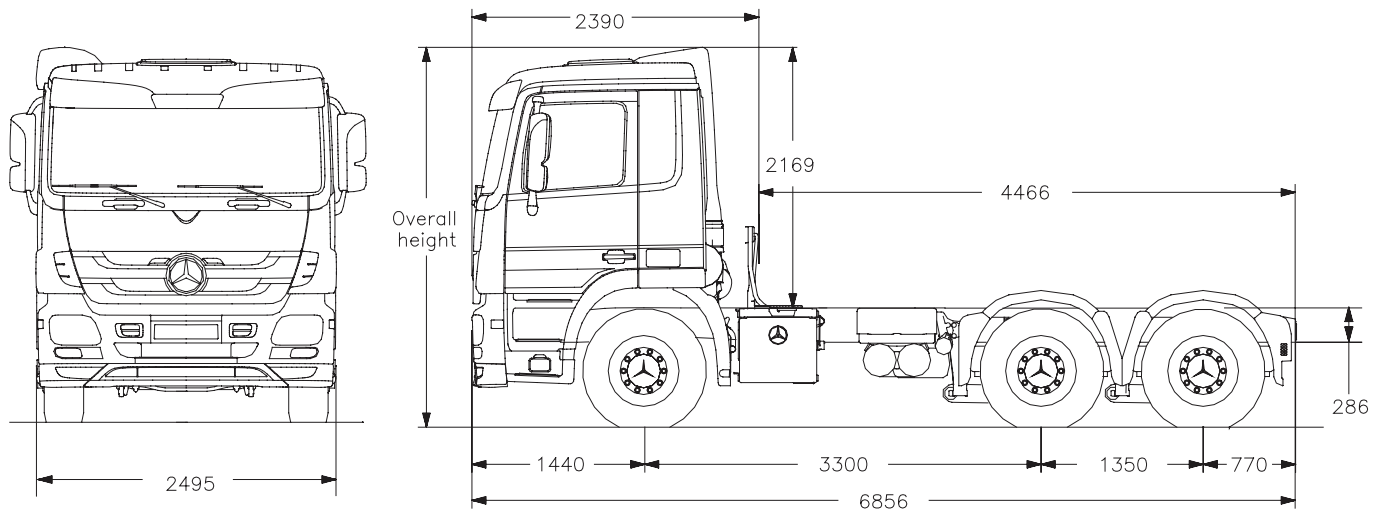

Note: drawings are general arrangement drawings only. Contact your authorised Dealer for details if required.

### Weights

Tare	Steel suspension	Air suspension
Front axle	4,766 kg	4,841 kg
Rear axles	3,468 kg	3,190 kg
Total	8,234 kg	8,031 kg
<b>Plated weights</b>		
Front axle	7,100 kg	7,100 kg
Rear axles	19,000 kg	19,000 kg
GVM	26,000 kg	26,000 kg
GCM	Up to 55,000 kg	Up to 55,000 kg

Weights and dimensions shown are to specifications with no fuel, full AdBlue, oil, water and tools. Tare weights are subject to a manufacturing tolerance of  $\pm 3\%$ . MBAuP reserves the right to alter specification or equipment without notice.

### Dimensions

	Steel suspension	Air suspension
Wheelbase	3,300 mm	3,300 mm
Frame height at rear axle (unladen)	1,100 mm	1,045 mm
Frame height at rear axle (laden)	991 mm	1,020 mm
Overall height (unladen)	3,554 mm	3,499 mm
Ground clearance front	278 mm	278 mm
Ground clearance rear	221 mm	249 mm
Cab tilt angle	70°	70°
Turning circle (wall to wall)	16.0 m	16.0 m
Frame width at rear	760 mm	760 mm

### Options

- Axle ratio 3.431
- 3050 mm wheelbase
- Low cab roof
- Long cab
- MegaSpace cab
- Air deflector cab roof
- Aerodynamic fairing with side air deflectors
- Wood trim dashboard
- Refrigerator
- Driver's and passenger's sunblind
- Chrome plated mirrors
- Dual plate clutch
- Bi-xenon headlamps
- Fuel tank package 550 litre RHS
- Fuel tank package 550 litre RHS & 450 litre LHS
- Front foglamps, halogen
- Painted grille
- Painted steps and bumper
- High output 100 Amp alternator
- Vertical exhaust outlet
- Air intake under cab
- Polished Alcoa rims
- PTOs
- Safety package includes:
  - Telligent® lane assistant
  - Telligent® proximity control
  - Voith retarder
- Grammer, comfort, co-driver seat
- Lower bunk, M-cab
- Upper bunk, L- and MegaSpace cabs

Authorised Dealer

To speak to your nearest authorised Mercedes-Benz Dealer call **1300 66 22 30**

**For full Warranty details and limitations contact your authorised Mercedes-Benz Truck Dealer.** IMPORTANT! This brochure has been compiled by Mercedes-Benz Australia/Pacific Pty Ltd to provide a general indication of the range of models available in Australia. Some of the models, features, optional extras and/or colours shown may not be available in Australia or may only be available in a different specification. Additionally, some models, features, optional extras and/or colours may only be available in combination with others. Some equipment depicted either on vehicle illustrations or separately may be non standard or options and may, where applicable, be available at an additional cost. For current information on the availability, design features and prices of all models, features, optional extras and/or colours available in Australia, you should contact your authorised Mercedes-Benz Truck Dealer on **1300 66 22 30** or go to [www.mercedes-benz.com.au/trucks](http://www.mercedes-benz.com.au/trucks). All of the information contained in this brochure was correct as at April 2011. However, the manufacturer reserves the right to discontinue, make changes to design and specifications to vehicles or optional equipment without notice. Mercedes-Benz Australia/Pacific Pty Ltd. ABN 23 004 411 410. Lexia Place, Mulgrave, Victoria 3170. Ph: (03) 9566 9266. Facsimile: (03) 9562 0397. The and the words Mercedes-Benz, Telligent® and BlueTec® are registered trademarks of Daimler AG, Stuttgart, Germany.