

# 2648, 2651, 2655, 2660

## 6x4 Heavy Duty Prime-mover Specifications

# Actros

125! years of innovation



**Mercedes-Benz**  
Trucks you can trust

### Engine

Type	Mercedes-Benz OM 501 LA 11.9 litre turbocharged V6 or Mercedes-Benz OM 502 LA 15.9 litre turbocharged V8 476 - 598 hp (1,696 - 2,065 lb.ft) (See Actros Engines brochure for complete engine specification details)
------	--

### Transmission

Type	Mercedes PowerShift G280-16/11.7-0.69 16 speed constant-mesh automated mechanical transmission  Mercedes PowerShift 2 G330-12/11.63-0.77 12 speed constant-mesh automated mechanical transmission with 2648
------	---

### Clutch

Type	Self-adjusting dual dry plate
Diameter	2 x 400 mm

### Axles

Front	Mercedes-Benz 7,500 kg capacity Straight front axle
Drive	Mercedes-Benz 2 x 13,000 kg capacity Planetary hub reduction 300 mm crown wheel Inter-axle and cross-axle differential locks
Ratio	4.143 - 1,480 rpm @ 100 km/h 3.714 - 1.505 rpm @ 100km/h with 2648

### Suspension

Front axle	Mercedes-Benz 3 leaf parabolic springs Stabiliser bar and shock absorbers 8,000 kg capacity
Rear axle steel	Mercedes-Benz 6 rod with parabolic springs Stabiliser bar and shock absorbers 2 x 9,500 kg capacity
Rear axle air	Mercedes-Benz 8 bag air suspension Stabiliser bar and shock absorbers 2 x 10,000 kg capacity Telligent® level control

### Tank capacity

Diesel tank	670 litre rectangular aluminium tank on RHS 530 litre rectangular aluminium tank on LHS
AdBlue tank	1 x 95 litre rectangular plastic tank on RHS for V8 1 x 85 litre rectangular plastic tank on RHS for V6

### Chassis

Main rail	286 mm web x 70 mm flange x 8.0 mm thickness High strength E 500 TM steel ECE-R93, Front Underrun Protection Device (FUPD)
Exhaust system	SCR catalytic converter with downswept outlet on LHS

### Brakes

Front/rear	Disc brakes 430 mm diameter Telligent® electro-pneumatic braking (EBS)
Service	10 bar operating pressure Automatic adjustment Air dryer ABS (anti-lock brakes) & ASR traction control Roll back prevention Telligent® Stability Control (ESP)* Active Brake Assist 2* autonomous emergency braking
Trailer	2 line trailer brakes with hand control Air and electrical lines behind cab
Engine brake	Active Engine Brake (AEB)

### Cab

Type	M (medium) cab ECE-R29 compliant cab Driver's airbag and seatbelt pre-tensioner (See Actros Cabins brochure for complete cab specification details)
------	--

### Steering

Type	Mercedes-Benz recirculating ball Integral power assistance Soft-feel 450 mm steering wheel Fully adjustable for height and rake
------	--

### Wheels and tyres

Wheels	10-stud 8.25 x 22.5 steel wheels
Tyres	Steer - 295/80 R 22.5 Drive - 11 R 22.5

### Electrical system

Voltage	24 volts
Batteries	2 x 12 V/165 Ah
Alternator	28 V/100 A
Starter	6.2 kW/24 V
Road lights	Halogen headlights
Fuses	Automatic fuses
Body Builder	Interface Module (PSM)

# Actros, 2648, 2651, 2655, 2660

## 6x4 Heavy Duty Prime-mover Specifications

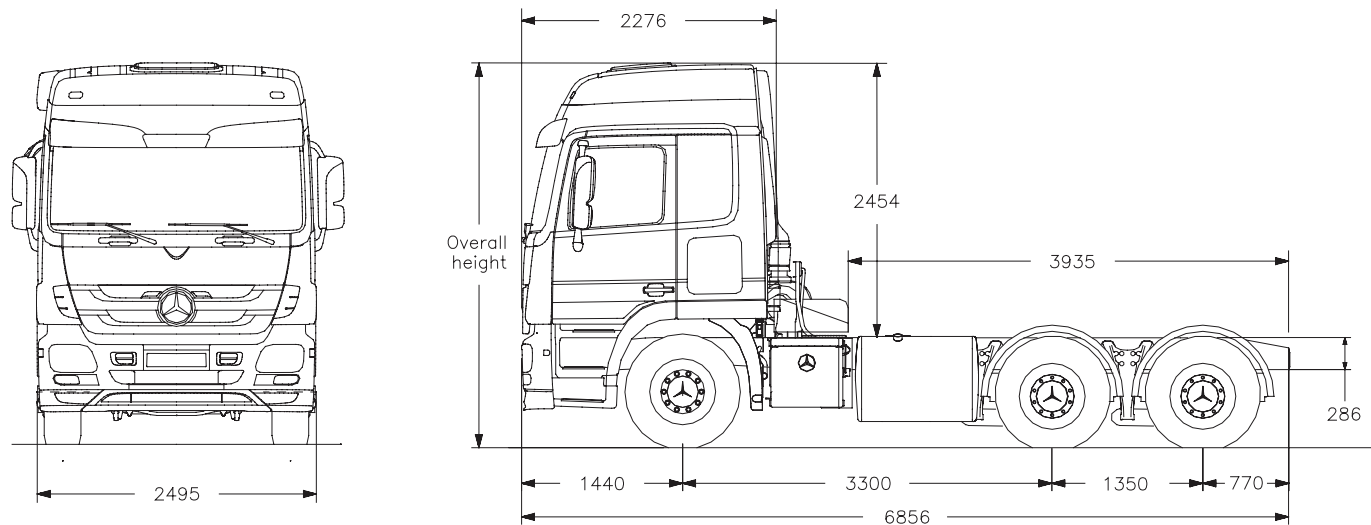

Note: drawings are general arrangement drawings only. Contact your authorised Dealer for details if required. (Long cab shown)

### Weights

Tare	V6 Steel	V6 Air	V8 Steel	V8 Air
Front axle	4,793 kg	4,868 kg	4,916 kg	5,011 kg
Rear axles	3,630 kg	3,352 kg	3,655 kg	3,377 kg
Total	8,423 kg	8,220 kg	8,571 kg	8,388 kg
Plated weights				
Front axle	7,100 kg	7,100 kg	7,100 kg	7,100 kg
Rear axles	19,000 kg	19,000 kg	19,000 kg	19,000 kg
GVM	26,000 kg	26,000 kg	26,000 kg	26,000 kg
GCM	70,000 kg	70,000 kg	90,000 kg	90,000 kg

Weights and dimensions shown are to specifications with no fuel, full AdBlue, oil, water and tools. Tare weights are subject to a manufacturing tolerance of  $\pm 3\%$ . MBAuP reserves the right to alter specification or equipment without notice.

### Dimensions

	Steel suspension	Air suspension
Wheelbase	3,300 mm	3,300 mm
Frame height at rear axle (unladen)	1,100 mm	1,045 mm
Frame height at rear axle (laden)	991 mm	1,020 mm
Overall height (unladen)	3,624 mm	3,569 mm
Ground clearance front	348 mm	348 mm
Ground clearance rear	221 mm	249 mm
Cab tilt angle	70°	70°
Turning circle (wall to wall)	16.0 m	16.0 m
Frame width at rear	760 mm	760 mm

### Options

- Axle ratio 4.333
- 3,050 mm wheelbase
- Low cab roof
- Long cab
- MegaSpace cab
- Air deflector cab roof
- Aerodynamic fairing with side air deflectors
- Wood trim dashboard
- Refrigerator
- Driver's and passenger's sunblind
- Chrome plated mirrors
- Bi-xenon headlamps
- Fuel tank package 550 litre RHS
- Front foglamps, halogen
- Painted grille
- Painted steps and bumper
- Vertical exhaust outlet
- Polished Alcoa rims
- PTOs
- Safety package includes:
  - Telligent<sup>®</sup> lane assistant
  - Telligent<sup>®</sup> proximity control
  - Voith retarder
- Grammer, comfort, co-driver seat
- Lower bunk, M-cab
- Upper bunk, L- and MegaSpace cabs

Authorised Dealer

To speak to your nearest authorised Mercedes-Benz Dealer call **1300 66 22 30**

**For full Warranty details and limitations contact your authorised Mercedes-Benz Truck Dealer.** IMPORTANT! This brochure has been compiled by Mercedes-Benz Australia/Pacific Pty Ltd to provide a general indication of the range of models available in Australia. Some of the models, features, optional extras and/or colours shown may not be available in Australia or may only be available in a different specification. Additionally, some models, features, optional extras and/or colours may only be available in combination with others. Some equipment depicted either on vehicle illustrations or separately may be non standard or options and may, where applicable, be available at an additional cost. For current information on the availability, design features and prices of all models, features, optional extras and/or colours available in Australia, you should contact your authorised Mercedes-Benz Truck Dealer on **1300 66 22 30** or go to [www.mercedes-benz.com.au/trucks](http://www.mercedes-benz.com.au/trucks). All of the information contained in this brochure was correct as at April 2011. However, the manufacturer reserves the right to discontinue, make changes to design and specifications to vehicles or optional equipment without notice. Mercedes-Benz Australia/Pacific Pty Ltd. ABN 23 004 411 410. Lexia Place, Mulgrave, Victoria 3170. Ph: (03) 9566 9266. Facsimile: (03) 9562 0397. The and the words Mercedes-Benz, Telligent<sup>®</sup> and BlueTec<sup>®</sup> are registered trademarks of Daimler AG, Stuttgart, Germany.