

1833 A

4x4 All Wheel Drive Specifications

Axor

125! years of innovation



Mercedes-Benz
Trucks you can trust

Engine

Type	Mercedes-Benz OM 926 LA 7.2 litre turbocharged in-line 6 326 hp (960 lb.ft) Euro 5 with EEV (See Axor Engines brochure for complete engine specification details)
------	---

Transmission

Type	Mercedes Benz G131 – 9/14.6 – 1.00 9 speed synchromesh transmission Mechanical gearshift
------	---

Transfer Case

Type	Mercedes Benz VG 1700 – 3W, 2 gear
On-road	1.00:1
Off-road	1.403:1

Clutch

Type	Self-adjusting single dry plate
Diameter	430 mm

Axles

Front	Mercedes-Benz 7,500 kg capacity
Drive	Mercedes-Benz 13,000 kg capacity Planetary hub reduction 300 mm crown wheel Differential lock
Ratio	4.143 -2,085 rpm @ 100 km/h

Suspension

Front axle	Mercedes-Benz 3 leaf parabolic springs Stabiliser bar and shock absorbers 7,500 kg capacity
Rear axle air	Mercedes-Benz 4 leaf parabolic springs Stabiliser bar and shock absorbers 11,500 kg capacity

Tank capacity

Diesel tank	1 x 400 litre rectangular aluminium tank on RHS
AdBlue tank	1 x 35 litre rectangular plastic tank on RHS

Chassis

Main rail	289 mm web x 70 mm flange x 9.5 mm thickness High strength E 500 TM steel
Exhaust system	SCR catalytic converter with downswept outlet LHS

Brakes

Front/rear	Drum brakes 410 mm diameter Automatic adjustment Air dryer Load sensing brakes ABS (anti-lock brakes) ABS de-activation switch
Engine brake	Active Engine Brake (AEB)

Cab

Type	S (short) cab ECE-R29 compliant cab CD Radio with Bluetooth (See Axor Cabins brochure for complete cab specification details)
------	--

Steering

Type	Mercedes-Benz recirculating ball Integral power assistance Soft-feel 450 mm steering wheel Fully adjustable for height and rake
------	--

Wheels and tyres

Wheels	10-stud 9.00 x 22.5 steel wheels
Tyres	Steer – 315/80R 22.5 Bridgestone M840 Drive – 315/80R 22.5 Bridgestone M840

Electrical system

Voltage	24 volts
Batteries	2 x 12 V/220 Ah
Alternator	28 V/80 A
Starter	4 kW/24 V
Road lights	Halogen headlights
Fuses	Automatic fuses
Body Builder	Interface Module (PSM)

Axor, 1833 A

4x4 All Wheel Drive Specifications

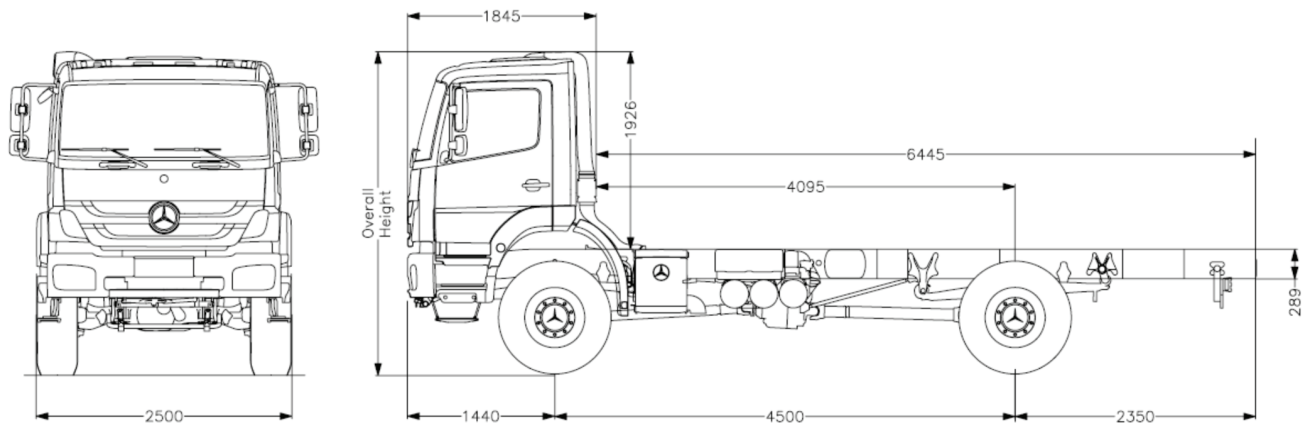

Note: drawings are general arrangement drawings only. Contact your authorised Dealer for details if required.

Weights

Tare

Front axle	4,507 kg
Rear axles	2,425 kg
Total	6,932 kg

Plated weights

Front axle	7,100 kg
Rear axles	11,500 kg
GVM	18,000 kg
GCM	36,000 kg
(39,000 kg with G211-16 transmission)	

Weights and dimensions shown are to specifications with no fuel, full AdBlue, oil, water and tools. Tare weights are subject to a manufacturing tolerance of $\pm 3\%$. MBAuP reserves the right to alter specification or equipment without

Dimensions

	Air suspension
Wheelbase	4,500 mm
Frame height at rear axle (unladen)	1,303 mm
Frame height at rear axle (laden)	1,177 mm
Overall height (unladen)	3,229 mm
Ground clearance front	355 mm
Ground clearance rear	334 mm
Cab tilt angle	55°
Turning circle (wall to wall)	18.2 m
Frame width at rear	763 mm

Wheelbases	Wheelbase	Overhang
1833A/42	4,200 mm	2,100 mm
1833A/45	4,500 mm	2,350 mm

Options

- Axle ratio 4.333
- Telephone/Fax provision
- Extended short cab
- Grammer, comfort, co-driver seat
- Wood trim dash
- Leather steering wheel
- CD storage box
- In cab cooler box
- Upright exhaust outlet
- Fog lights
- Painted bumper
- Painted grille
- PTO's

Authorised Dealer

To speak to your nearest authorised Mercedes-Benz Dealer call 1300 66 22 30

For full Warranty details and limitations contact your authorised Mercedes-Benz Truck Dealer. IMPORTANT! This brochure has been compiled by Mercedes-Benz Australia/Pacific Pty Ltd to provide a general indication of the range of models available in Australia. Some of the models, features, optional extras and/or colours shown may not be available in Australia or may only be available in a different specification. Additionally, some models, features, optional extras and/or colours may only be available in combination with others. Some equipment depicted either on vehicle illustrations or separately may be non standard or options and may, where applicable, be available at an additional cost. For current information on the availability, design features and prices of all models, features, optional extras and/or colours available in Australia, you should contact your authorised Mercedes-Benz Truck Dealer on 1300 66 22 30 or go to www.mercedes-benz.com.au/trucks. All of the information contained in this brochure was correct as at April 2011. However, the manufacturer reserves the right to discontinue, make changes to design and specifications to vehicles or optional equipment without notice. Mercedes-Benz Australia/Pacific Pty Ltd. ABN 23 004 411 410. Lexia Place, Mulgrave, Victoria 3170. Ph: (03) 9566 9266. Facsimile: (03) 9562 0397. The and the words Mercedes-Benz, Telligent® and BlueTec® are registered trademarks of Daimler AG, Stuttgart, Germany.