

2533

## 6x2 Rigid Specifications

## Axor

125! years of innovation



Mercedes-Benz  
Trucks you can trust

---

**Engine**

Type	Mercedes-Benz OM 926 LA 7.2 litre turbocharged in-line 6 326 hp (960 lb.ft) Euro 5 with EEV (See Axor Engines brochure for complete engine specification details)
------	---

---

**Transmission**

Type	Mercedes Benz G131 - 9/14.6 - 1.00 9 speed synchromesh transmission Mechanical gearshift
Type (optional)	Mercedes Benz G211 - 16/17.0 - 1.00 16 speed synchromesh transmission Telligent® electronic gearshift (3 pedal)

---

**Clutch**

Type	Self-adjusting single dry plate
Diameter	430 mm

---

**Axles**

Front	Mercedes-Benz 7,500 kg capacity
Drive	Mercedes-Benz 13,000 kg capacity Hypoid reduction 440 mm crown wheel Differential lock
Tag	Mercedes-Benz 10,500 kg capacity
Ratio	3.077 - 1,585 rpm @ 100 km/h

---

**Suspension**

Front axle	Mercedes-Benz 2 leaf parabolic springs Stabiliser bar and shock absorbers 7,100 kg capacity
Rear axle air	Mercedes-Benz 8 bag air suspension Stabiliser bar and shock absorbers 2 x 10,000 kg capacity Telligent® level control

---

**Tank capacity**

Diesel tank	1 x 400 litre rectangular aluminium tank on RHS
AdBlue tank	1 x 95 litre rectangular plastic tank on RHS

---

**Chassis**

Main rail	284 mm web x 70 mm flange x 7.0 mm thickness High strength E 500 TM steel Front Underrun Protection Device (FUPD)
Exhaust system	SCR catalytic converter with downswept outlet LHS

---

**Brakes**

Front/rear	Disc brakes 430 mm diameter Automatic adjustment Air dryer Load sensing brakes ABS (anti-lock brakes) ASR traction control
Trailer	2 line trailer brakes with hand control Air and electrical lines at rear of frame
Engine brake	Active Engine Brake (AEB)

---

**Cab**

Type	S (short) cab ECE-R29 compliant cab Drivers airbag and seatbelt pre-tensioner CD Radio with Bluetooth (See Axor Cabins brochure for complete cab specification details)
------	---

---

**Steering**

Type	Mercedes-Benz recirculating ball Integral power assistance Soft-feel 450 mm steering wheel Fully adjustable for height and rake
------	--

---

**Wheels and tyres**

Wheels	10-stud 8.25 x 22.5 steel wheels
Tyres	Steer - 295/80R 22.5 Bridgestone R 150 Drive - 11R 22.5 Bridgestone M711 Tag - 295/80R 22.5 Bridgestone R 150

---

**Electrical system**

Voltage	24 volts
Batteries	2 x 12 V/165 Ah
Alternator	28 V/80 A
Starter	4 kW/24 V
Road lights	Halogen headlights
Fuses	Automatic fuses
Body Builder	Interface Module (PSM)

# Axor, 2533

## 6x2 Rigid Specifications

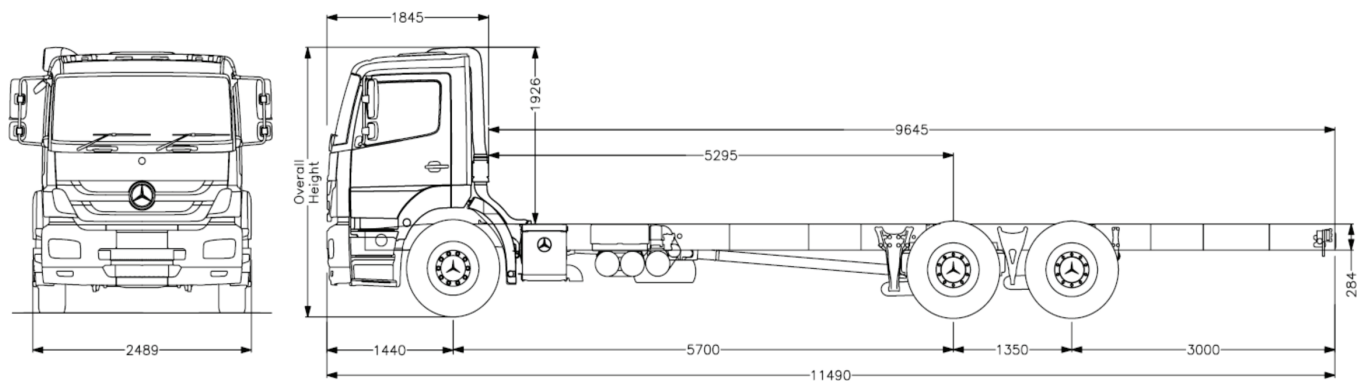

Note: drawings are general arrangement drawings only. Contact your authorised Dealer for details if required.

### Weights

Tare	
Front axle	3,785 kg
Rear axles	3,450 kg
Total	7,235 kg
Plated weights	
Front axle	7,100 kg
Rear axles	2 x 9,500 kg
GVM	25,000 kg
GCM	36,000 kg
(39,000 kg with G211-16 transmission)	

Weights and dimensions shown are to specifications with no fuel, full AdBlue, oil, water and tools. Tare weights are subject to a manufacturing tolerance of ±3%. MBAuP reserves the right to alter specification or equipment without

### Dimensions

Air suspension		
Wheelbase	5,700 mm	
Frame height at rear axle (unladen)	1,061 mm	
Frame height at rear axle (laden)	990 mm	
Overall height (unladen)	2,987 mm	
Ground clearance front	275 mm	
Ground clearance rear	220 mm	
Cab tilt angle	55°	
Turning circle (wall to wall)	22.3 m	
Frame width at rear	758 mm	
Wheelbases	Wheelbase	Overhang
1833L/54	5,400 mm	3,000 mm
1833L/57	5,700 mm	3,000 mm

### Options

- Axle ratio 3.583
- Telephone/Fax provision
- Extended short cab
- Long cab
- High roof sleeper
- Grammer, comfort, co-driver seat
- Seat/bunk combination
- Upper bunk
- Air deflectors
- Rear side windows
- Wood trim dash
- Leather steering wheel
- CD storage box
- In cab cooler box
- Extended fuel tank package
- Upright exhaust outlet
- Fog lights
- Painted bumper
- Painted grille
- PTO's
- Alcoa Aluminium rims

Authorised Dealer

To speak to your nearest authorised Mercedes-Benz Dealer call **1300 66 22 30**

**For full Warranty details and limitations contact your authorised Mercedes-Benz Truck Dealer.** IMPORTANT! This brochure has been compiled by Mercedes-Benz Australia/Pacific Pty Ltd to provide a general indication of the range of models available in Australia. Some of the models, features, optional extras and/or colours shown may not be available in Australia or may only be available in a different specification. Additionally, some models, features, optional extras and/or colours may only be available in combination with others. Some equipment depicted either on vehicle illustrations or separately may be non standard or options and may, where applicable, be available at an additional cost. For current information on the availability, design features and prices of all models, features, optional extras and/or colours available in Australia, you should contact your authorised Mercedes-Benz Truck Dealer on **1300 66 22 30** or go to [www.mercedes-benz.com.au/trucks](http://www.mercedes-benz.com.au/trucks). All of the information contained in this brochure was correct as at April 2011. However, the manufacturer reserves the right to discontinue, make changes to design and specifications to vehicles or optional equipment without notice. Mercedes-Benz Australia/Pacific Pty Ltd. ABN 23 004 411 410. Lexia Place, Mulgrave, Victoria 3170. Ph: (03) 9566 9266. Facsimile: (03) 9562 0397. The  and the words Mercedes-Benz, Telligent® and BlueTec® are registered trademarks of Daimler AG, Stuttgart, Germany.